

DIN FLANGED GLOBE VALVE NP25

MAIN SPECIFICATIONS

Nominal pressure: **2.5MPa**
 Shell test: **3.75MPa**
 Seal test: **2.75MPa (Water) 0.6MPa (Gass)**
 APLICABLE MEDIUM: **WATER, OIL, STEAM**
 APLICABLE TEMPERATURE: **<= C-425°C**
 MAIN MATERIAL: **WCB**

MAIN PARAMETER SPECIFICATIONS

Design and manufacture: **DIN3356**
 Face to face: **DIN3202**
 Connection dimensions: **DIN2544**
 Pressure test: **API598**

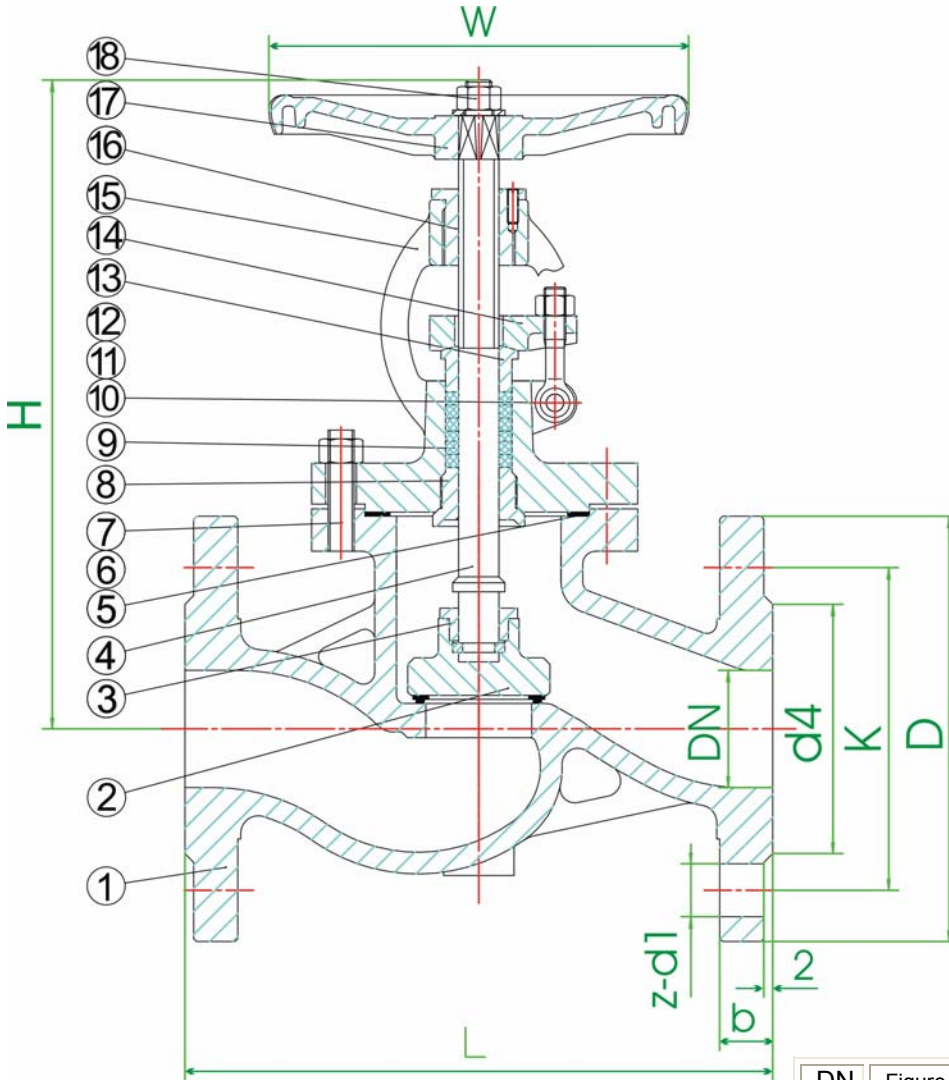

18	H.W. Lock Nut	AISI 1035
17	Handwheel	KTH300-06
16	Stem Nut	ZCuAl10Fe3
15	Bonnet	A216 WCB
14	Gland Flange	A216 WCB
13	Gland	A182 F6
12	Gland Nut	A194 2H
11	Gland Eyebolt	A193 B7
10	Pin	45
9	Stem Packing	Graphite
8	Backseat	A182 F6
7	Bonnet Nut	A194 2H
6	Bonnet Bolt	A193 B7
5	Gasket	SS304+Graphite
4	Stem	A182 F6
3	Disc nut	A182 F6
2	Disc	A105+13Cr
1	Body	A216 WCB

DN	Figure dimensions			Flange dimensions					
	L	H~	W	D	K	d	b	f	z-d1
15	130	115	80	95	65	45	16	2	4-φ14
20	150	115	100	105	75	58	18	2	4-φ14
25	160	145	120	115	85	68	18	2	4-φ14
32	180	170	140	140	100	78	18	2	4-φ18
40	200	185	180	150	110	88	18	2	4-φ18
50	230	200	200	165	125	102	20	2	4-φ18
65	290	230	250	185	145	122	22	2	8-φ18
80	310	380	280	200	160	138	24	2	8-φ18
100	350	425	300	235	190	162	24	2	8-φ22
125	400	485	350	270	220	188	26	2	8-φ26
150	480	570	350	300	250	218	28	2	8-φ26
200	600	650	400	360	310	278	30	2	12-φ26