

DIN FLANGED BALL VALVE NP 25

MAIN SPECIFICATIONS

Nominal pressure: **2.5MPa**
 Shell test: **3.75MPa**
 Seal test: **2.75MPa (Water) 0.6MPa (Gass)**
 APLICABLE MEDIUM: **WATER, OIL, STEAM**
 APLICABLE TEMPERATURE: **<= C-425°C**
 MAIN MATERIAL: **WCB**

PARAMETER SPECIFICATIONS

Design and manufacture: **DIN3357**
 Socket and dimensions: **DIN2544**
 Pressure-Temperature: **ASME / ANSI B16.34.**
 Pressure test: **API598**

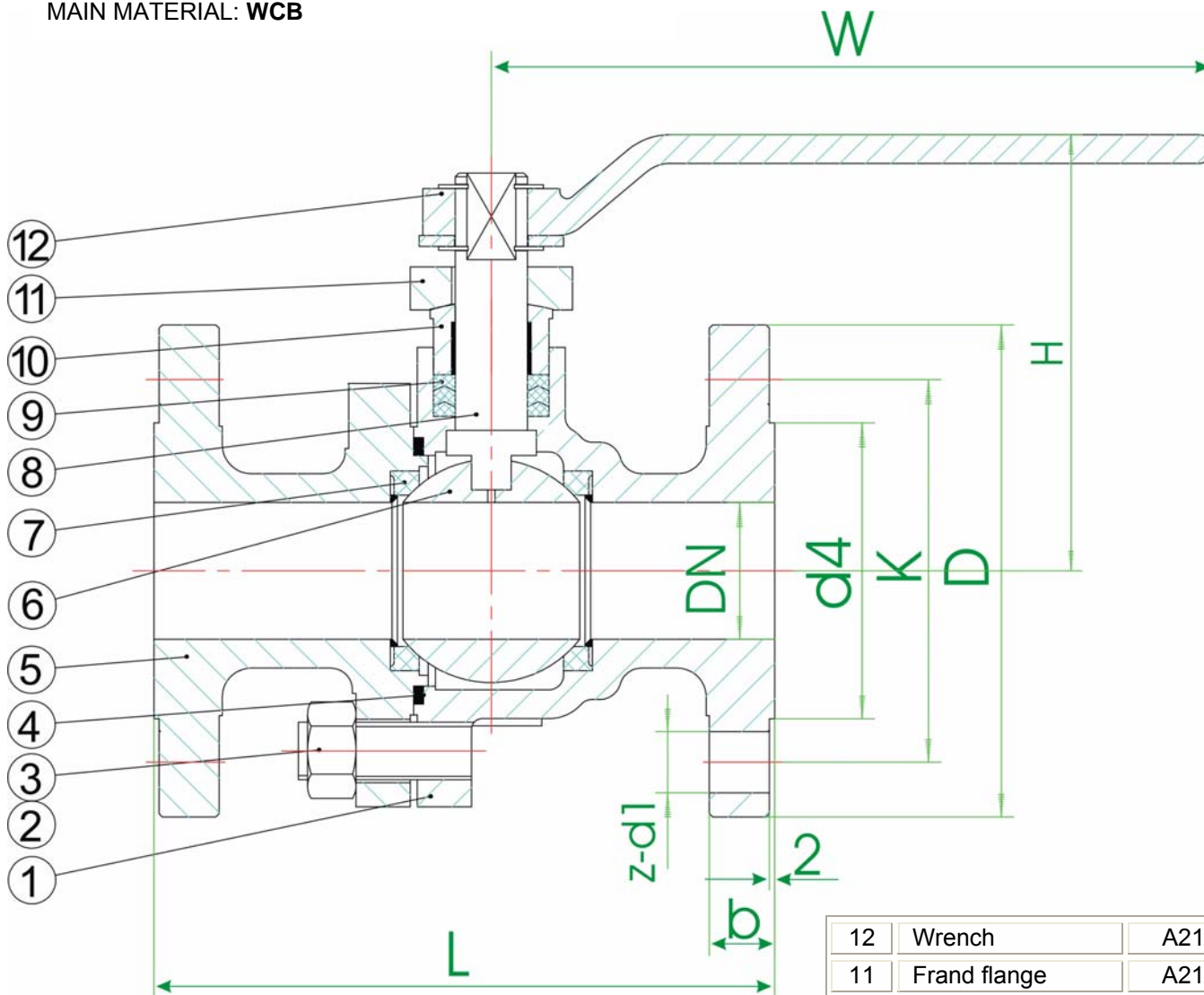

12	Wrench	A216 WCB
11	Frاند flange	A216 WCB
10	Gland	A182 F6
9	Stem packing	PTFE
8	Stem	A182 F304
7	Seat	PTFE
6	Ball	A182 F304
5	Body cap	A216 WCB
4	Body seal	PTFE
3	Body stud nut	A194 2H
2	Body stud	A193 B7
1	Body	A216 WCB

DN	Figure dimensions			Flange dimensions				
	L	H~	W~	D	K	d4	b	z-d1
50	200	190	350	165	125	102	20	4-φ18
65	220	195	350	185	145	122	22	8-φ18
80	250	215	400	200	160	138	24	8-φ18
100	280	250	500	235	190	162	24	8-φ22
125	320	285	600	270	220	188	26	8-φ26
150	360	330	700	300	250	218	28	8-φ26
200	400	370	800	360	310	278	30	12-φ26